

TROMPLAT 1250

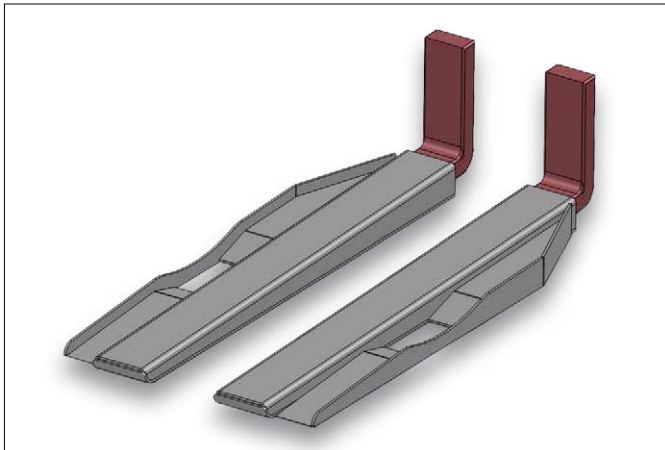

Fig. 1: TROMPLAT 1250

TROMPLAT 1600

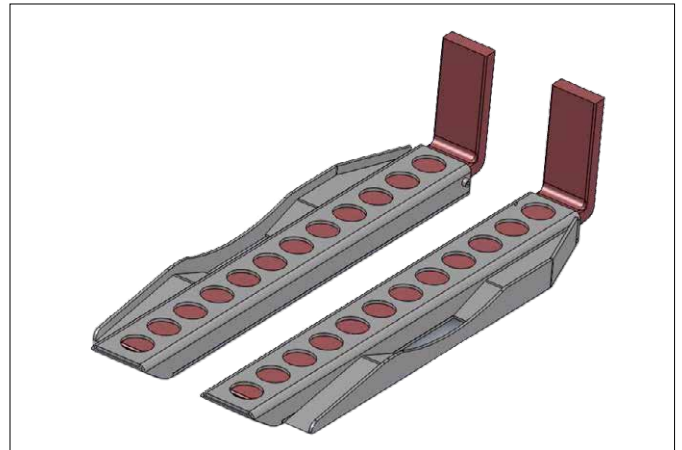

Fig. 2: TROMPLAT 1600



Fig. 3: TROMPLAT 1250 application example



Fig. 4: TROMPLAT 1600 application example

This loading device for cable drums allows a time-saving and safety storing and removal of cable drums, in and out of a dynamic cable drum storage.

Mode of operation:

This transport and loading accessory consists of two plat forms (extensions) which are put on the forks and fixed by clamping levers. By changing these accessories from the right to the left and vice versa they can either be used for small drums as well as for bigger ones.

The drum is simply rolled away on the floor. To avoid that the drum falls out, it must rest in centering position

Note: Perfect for forklifts with hydraulically adjustable forks

	TROMPLAT 1250 Article-No. 87000310	TROMPLAT 1600 Article-No. 87000311
Length	1250 mm	1600 mm
Load capacity	1000 kg	2500 kg
Weight	60 kg / pair	150 kg / pair
Colour	RAL 7005 mousegrey	

Set of Stop Block TROMSTOP



For safe transportation and to place drum into stock via pallet stacker



TROMSTOP Standard configuration

Production after note your fork dimensions

Article-No. 85100147

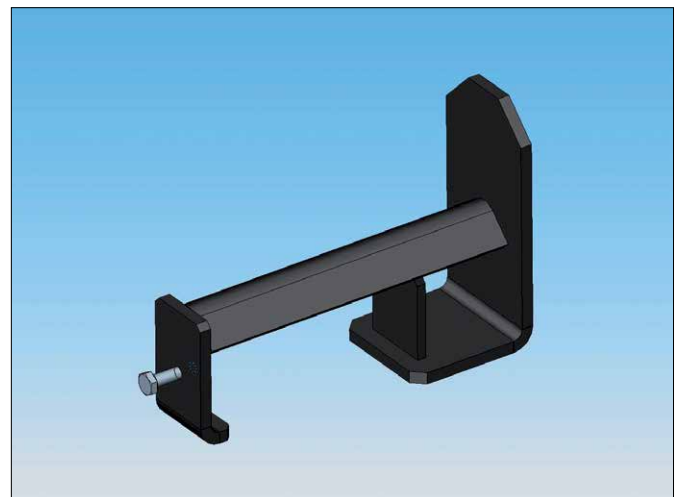

TROMSTOP Width configuration

For drums, which are wider than the fork outside dimensions
Production after note your fork dimensions

Article-No. 86180045